

A Simple Direction-Finding Receiver for 80 Meters

Dale Hunt, WB6BYU



KUON HUNT, KB7WRG

Transmitter hunting is a fun sport, and 80 meters is a good band for beginners because it is not subject to the reflections and multipath distortion of signals that can be confusing on VHF. Amateur Radio Direction Finding (ARDF) international competitions include 80 meter events where competitors run through the forest hunting transmitters with a hand-held receiver.^{1,2,3} This is an excellent activity for Scouting or orienteering groups, as well as hams.

Meanwhile, our HF bands are subjected to an increasing amount of interference from electrical equipment, home electronics, touch lamps and other sources. You can use this hand-held receiver to track interference as well as hidden transmitters.

Receivers that cover 80 meters and are suitable for ARDF have not been easily available in the US, so competitors have used equipment from Russia, Germany, Australia or China.⁴ Several good designs have been published in European amateur journals, but have not been available in English. Some use parts not readily available in North America.^{5,6} The simple receiver described

*Join the fun
of the "hunt" with
this easy-to-build
little receiver.*

*It makes an
effective
interference
tracker, too.*

Title photo: The author takes a bearing on the run with a kit version of the completed receiver. His headphone is sewn into the blue sweatband, and the blue wires to it run down his right sleeve. Dale's map and compass are in his left hand.

here uses common parts and can be modified for other bands as well.

The design goals for this receiver were:

- Performance adequate to hear a 1 W signal from 3 miles away.
- Low battery drain.
- Easy-to-build using readily available parts.
- Lightweight, rugged and easy to operate.

It is worth noting that this is not a high-performance receiver by conventional standards. The bandwidth is ± 10 kHz, and the tuning rate is more than 100 kHz per revolution of the tuning knob. This is a practical combination for tuning in CW signals in a sparsely populated band while you are running on foot, but finer tuning is recommended for SSB signals or for other Amateur Radio use.

Circuit Description

There is nothing new about the basic circuit (see Figures 1 and 2). It is a direct conversion receiver^{7,8} using five generic NPN transistors such as the 2N3904 or 2N2222 and two common ICs. A four-turn loop antenna (L1) is tuned to resonance by capacitors C13 and C14, providing the only RF selectivity. The loop alone has a bidirectional

¹Notes appear on page 42.

pattern. The sense antenna can be switched in to create a unidirectional (cardioid) pattern, as shown in Figure 3. A shielded one-turn coupling loop (L2) feeds the signal to the cascode RF amplifier⁹ stage (Q1, Q2). The cascode circuit provides good sensitivity and convenient gain control, and also provides good isolation to reduce the feedthrough of the oscillator signal to the antenna. A wideband transformer, T1, couples the signal to the mixer.

The balanced mixer uses four common 1N4148 switching diodes (D1-D4). D6 and D7 are varactors to tune the VFO. A common-base audio preamp^{10,11} terminates the mixer and drives an LM386 audio amplifier. The receiver draws around 10 mA at normal audio levels, so a 9 V battery will provide many hours of use.

An LM2931Z-5.0 or other low dropout (LDO) regulator is highly recommended for U2. These units draw less than 1 mA and maintain output regulation with inputs down to 5.5 V. A conventional 78L05 regulator draws up to 3 mA and loses regulation when the battery voltage drops to 7.5 V. Much of the rated life of a 9 V battery is below this level, so using an LDO may give more than double the useful service from the same battery.

Construction

Figures 4 and 5 show two versions of the receiver. A PC board and kit are available, though ugly construction will work as well.¹² The circuit can be built in stages, testing each as you go. Touching a finger to the input of the audio amplifier or the mixer diodes should produce a noticeable buzz in the headphones.

The oscillator operates at the desired receive frequency. It can be set by adjusting L4 and/or C30 while checking the frequency with a counter or by listening for the signal with an 80 meter receiver. Frequencies in the range of 3.5 to 3.6 MHz are generally used for international competitions, but you should be able to cover the whole band by readjusting the coil slug. The TUNING control (R12) should cover a 50 to 100 kHz range at any one setting of L4. D6 and D7 can be varactors or ordinary Zener diodes. See the sidebar "Substituting Parts" for more discussion.

With the parts values specified for the VFO components, capacitor C30 usually will not be necessary. However, it allows for an additional fixed or trimmer capacitor if needed because of parts variations.

T1 is most easily wound on an FT-37-43 core, though other sizes can be used. See Figure 6 for detailed winding instructions. Once you have the receiver working, the core should be secured so it doesn't vibrate and break the leads. A spot of glue, a thin tie-wrap or a piece of string

tied through the holes on the circuit board will do the trick.

The mechanical construction is rugged, but requires no special tools. The antenna loop is formed from an 18 inch length of $\frac{3}{8}$ or $\frac{1}{2}$ inch diameter plastic tubing, bent into a circle and glued to the case. (The milky-white "poly" tubing works well.)

To make the loop housing, drill a hole in opposing sides of the case the same size as the plastic tubing. Form the tubing into a loop, insert one end in each hole, and secure with hot-melt glue or epoxy. Then cut five pieces of insulated wire several inches longer than the tubing. Tape these wires to a length of RG-174 miniature coaxial cable and work the whole bundle into one end of the tube and out the other end. The shield of the RG-174 is grounded only at the end that connects to C1. The center conductor is grounded at the other end, but the shield is insulated with a piece of tape or heatshrink tubing. Figure 7 shows the detailed connections of the loop wires. The actual loop size is not critical as long as C13 plus C14 can tune it to resonance.

The inductance of the tuned loop antenna varies depending on how it is mounted. The wire type may also make a difference. The most common problem is that when the ends of the tubing are too close together, the inductance is too low and tuning capacitance provided by the combination of C13 and C14 isn't enough. In the prototypes shown in Figures 4 and 5, the loop ends are about 1.75 and 2.5 inches apart. The kit version, shown in Figure 8, uses a clever mounting system for the loop antenna but places the ends closer together. If you can't get the loop to tune, try moving the loop ends farther apart if you can, or increasing C13 to 240 or 270 pF.

A metal case is recommended, but plastic will work. Look for something easy to hold in your hand. The circuit board fits in a RadioShack 270-238 aluminum box ($5\frac{1}{4} \times 3 \times 2\frac{1}{8}$ inches). For smaller hands, a

wooden handle can be added to the bottom of the case as shown in the photos. The hand-wired ("ugly construction") prototype shown in the photos uses the Radio Shack 270-1804 plastic case (1x2x6 inches) which is a perfect size to hold. However, it is a tight squeeze—even with small potentiometers—if you want to put the battery inside the case. Otherwise the battery can be taped to the back. If you are going to use the receiver with a compass, the case should have a minimum of ferrous metal.

The RF GAIN control gets the most use, so it should be convenient to operate with one of your fingers holding the case (or your other hand). The knob should have a pointer so you can tell how strong the signal is—this helps to judge the distance to the transmitter. The SENSE ANTENNA switch, S1, can be put where your index finger can work it easily (like a trigger). The VFO knob should have a fairly large diameter for easy tuning, but should be relatively flat against the case to make it harder to bump the receiver off frequency accidentally.

Alignment

First, adjust L4 to put the VFO in the desired frequency range. The loop can be tuned close to resonance with a dip meter. Final adjustment is by peaking C14 for maximum received signal at the desired frequency. You should be able to hear the background noise peak when the loop is tuned to resonance. Sensitivity should be adequate at ± 50 kHz. Tuning across the band in the evening, you should be able to copy QSOs.

The only additional adjustment is the sense antenna. A 6 inch whip or piece of wire strung from the case to the far side of the loop housing provides plenty of signal. I've also used a flexible wire hanging out the bottom of the case. (The circuit accommodates a wide range of sense antenna lengths.) R23 is used to set the sense antenna signal level. To work properly, R23 must be adjusted so that the signal

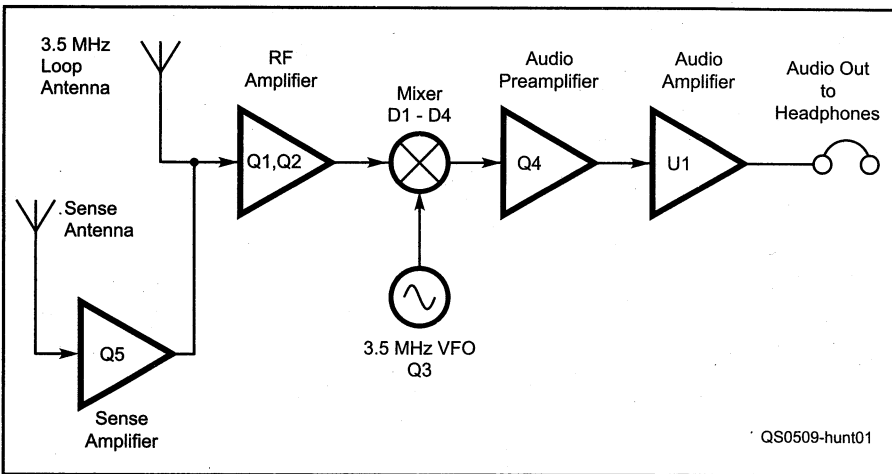
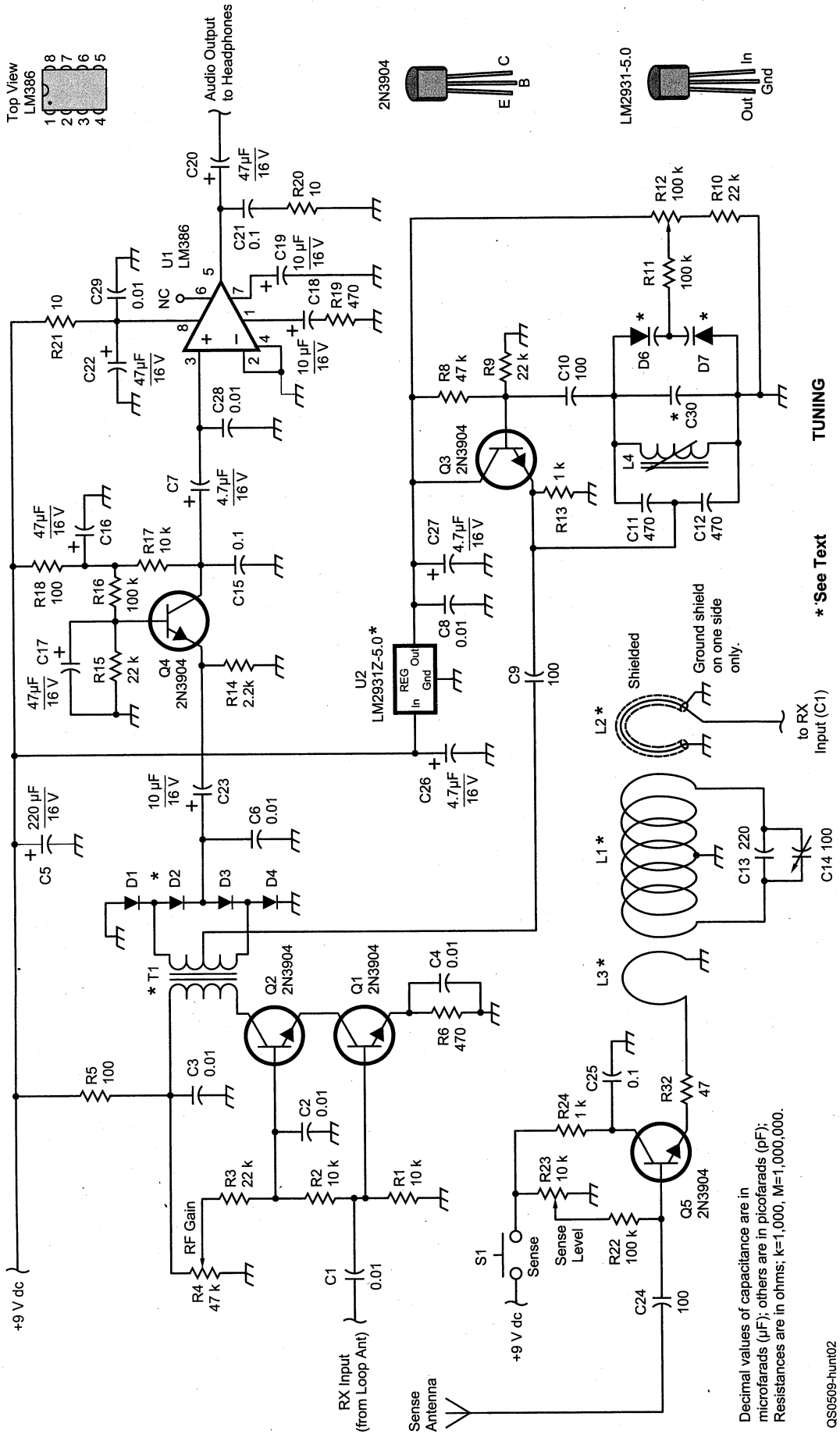

Figure 1—Block diagram of the simple direct-conversion 80 meter DF receiver.



Substituting Parts

Figure 2—Schematic diagram and parts list for the 80 m DF receiver. Most components are stocked by distributors such as DigiKey (www.digikey.com), Mouser (www.mouser.com), RadioShack (www.radioshack.com) and Dan's Small Parts (www.danssmallpartsandkits.com). Resistors can be 1/4 or 1/8 W, standard 20% values unless otherwise noted.

- C1-C4, C6, C8, C28, C29—0.01 μ F capacitor.
 C5—220 μ F, 16 V electrolytic capacitor.
 C7, C26, C27—4.7 μ F, 16 V electrolytic.
 C9, C10, C24—100 pF capacitor.
 C11, C12—470 pF mica, NP0 or polystyrene capacitor. A different value may be needed depending on the inductor used for L4. See text and Table 1.
 C13—220 pF capacitor as needed to resonate loop.
 C14—100 pF trimmer capacitor as needed to resonate loop.
 C15, C21, C25—0.1 μ F capacitor.
 C16, C17, C20, C22—47 μ F, 16 V electrolytic capacitor.
 C18, C19, C23—10 μ F, 16 V electrolytic capacitor.
 C30—Fixed or trimmer capacitor as needed, see text.
 D1-D4—1N4148 diode.
 D5—Part number not used.
 D6, D7—Varactor diode (MV209, MV2109, BB104) or Zener diode (1N759, 1N963, 1N5240B, 1N5242B). See text.
 L1—4 turns, 6 inches diam. inside 18 inch length of poly tubing (see text and Figure 7).
 L2—1 shielded turn wound with L1 (see text and Figure 7).
 L3—1 turn wound with L1 (see text and Figure 7).
 L4—PC-board mount adjustable coil in the 6-10 μ H range. See text and Table 1.
 Q1-Q5—Small signal NPN transistor, 2N3904, 2N2222 or equiv.
 R1, R2, R17—10 k Ω .
 R3, R9, R10, R15—22 k Ω .
 R4—47 k Ω linear taper potentiometer.
 R5, R18—100 Ω .
 R6—470 Ω .
 R8—47 k Ω .
 R11, R16, R22—100 k Ω .
 R12—100 k Ω linear taper potentiometer.
 R13, R24—1 k Ω .
 R14—2.2 k Ω .
 R19—470 Ω (higher value may be needed; see text).
 R20, R21—10 Ω .
 R23—10 k Ω trimmer potentiometer.
 R7, R24-R31—Part numbers not used.
 R32—47 Ω .
 S1—Normally open pushbutton switch.
 T1—Primary: 16t #26 or #28 enameled wire on FT-37-43 ferrite core. Secondary: 4t bifilar. See text and Figure 6.
 U1—LM386 audio amplifier.
 U2—Low dropout 5 V, 100 mA voltage regulator, LM2931Z-5.0 or equiv. 78L05 can be substituted (see text).

The parts used in this receiver are generally not critical, and can be freely substituted based on the content of your junkbox. For D6 and D7, look for varactors with a listed capacitance around 20-40 pF. The MV209 or MV2109 from Dan's Small Parts and other sources will work just fine, as will the BB104 (a dual-package that will require some work to fit the PC board). Other suitable alternatives include the 1N5144, 1N5470, MV2107, MV2108 or BB605.

Ordinary Zener diodes can also be pressed into service as varactors for D6 and D7. For example, a 1N961 10 V Zener diode will tune about 35 to 55 pF with a 1 V to 5 V tuning voltage, similar to an MV2109. Higher voltage Zeners generally have less capacitance (a 36 V Zener measured 18 to 28 pF). Look for Zeners in the 10-15 V range, such as the 1N759, 1N963, 1N5240B or 1N5242B. The older 1N759 and 1N963 tend to offer more capacitance swing, and thus a wider tuning range. You can also try using two Zeners in parallel for more tuning range. Keep in mind that capacitance of Zener diodes may vary depending on manufacturer. A 1N4742A (12 V, 1 W) Zener from one manufacturer came in at 180-300 pF.

The VFO coil (L4) is probably the least common part. The receiver was originally designed around variable inductors in 10 mm cans, such as the TK1416-ND (6.8 μ H) or TK1206-ND (8.2 μ H) from Digi-Key. These inductors are falling victim to the shift away from leaded components and are now more difficult to find.

Other inductor values from at least 4 μ H to 20 μ H can be substituted with suitable changes to C11, C12 and C30. For example, a version with a 12-20 μ H inductor from

Dan's Small Parts at L4 required changing C11 and C12 to 180 pF. Rewinding a 455 kHz IF transformer with 20 turns of wire provided a 7-14 μ H coil for one prototype, and an unknown 10.7 MHz IF transformer was used in another.

The PC board is designed for a 10 mm can, but you can use 7 mm cans with a little creativity. Snip off all the leads except the two for the coil and bend the shield tabs horizontal. Then, with a bit of bending of the leads, the coil will fit into two adjacent holes on the board. This puts one of the 7mm coil leads into the middle hole of the 10 mm layout, rather than the two ends. This pad is not wired to the circuit, so an extra solder bridge is needed on the bottom. Short ground wires soldered to the case will help secure the can. As of this writing, Digi-Key has a better selection of 7 mm cans than 10 mm cans. See Table 1 for options.

Although an adjustable coil is strongly recommended because it makes it easier to set the oscillator on frequency, a fixed 10 μ H coil can be used instead. For example, you could use 45 turns of #26 wire on a T-50-2 core, 270 pF capacitors at C11/C12, and a 50 pF trimmer at C30. Another possibility is a 10 μ H RF choke.

If the coil has a high-permeability ferrite core (as might be found in an RF choke or a 455 kHz transformer), it may be susceptible to external magnetic fields. With one coil, the VFO shifted up to 100 Hz when the receiver was rotated because of the influence of the Earth's magnetic field on the core permeability.¹⁴ If this is a problem, mount the coil with its axis vertical.

L4 can be replaced with a crystal for fixed-frequency use. This is convenient for beginners, or if you always hunt on the same frequency.

Table 1
VFO Component Values

L4 Type	Part Number	Source	C11/C12	C30
10 mm, 4.7 μ H	TK1415-ND	Digi-Key	470 pF	100 pF
7 mm, 6.6 μ H	TK3115-ND	Digi-Key	470 pF	
7 mm, 10.7 μ H	TK2428-ND	Digi-Key	270 pF	
7 mm, 10.9 μ H	TK2430-ND	Digi-Key	220 pF	
7 mm, 11.8 μ H	TK2429-ND	Digi-Key	220 pF	
10 mm, 12-20 μ H		Dan's Sm. Parts	180 pF	
Fixed, 10 μ H		See text.	270 pF	50 pF

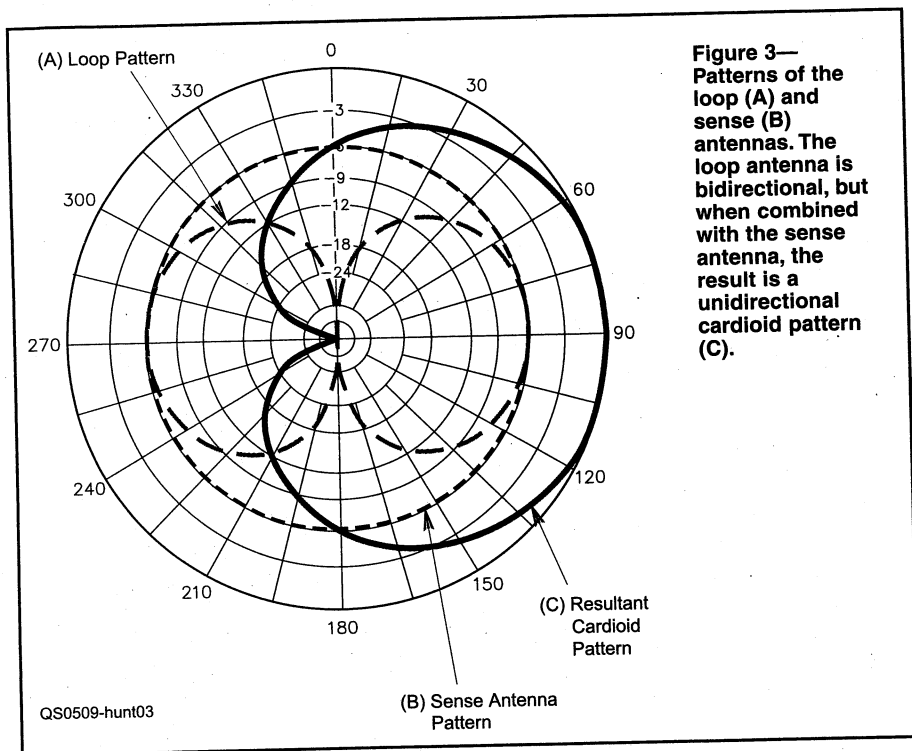

Figure 3—Patterns of the loop (A) and sense (B) antennas. The loop antenna is bidirectional, but when combined with the sense antenna, the result is a unidirectional cardioid pattern (C).

picked up on the sense antenna is the same level as the signal picked up on the loop. When so adjusted, the signals will add in one direction and cancel in the other, giving a single null in one of the directions where the loop had a peak. This null is not as sharp as those of the loop alone, so the sense antenna is generally used just to identify which of the two nulls on the loop points to the signal source.

A good distance for tuning a sense antenna is about one wavelength from the signal source, giving a reasonable compromise between far-field and near-field performance. Also, sense antenna performance will depend on height above ground, so make the adjustments at the

height where you will generally be holding the receiver while using it.

Set up a signal source about 250 to 300 feet away with a vertical antenna. Sense antenna adjustment should be done outdoors, away from the influence of power wires. If the receiver case is metal, the adjustment should be made with the case closed, so R23 should be accessible through a hole in the case.

Tune in the signal and rotate the receiver for peak signal from the loop. With the sense antenna off, adjust the loop tuning for maximum signal. Check that there are two nulls in the loop pattern, and that they are 180° apart. These nulls will be deepest when the plane of the loop is per-

pendicular to the line to the transmitter, so you look through the loop at the signal source. Position the receiver to null the received signal, then enable the sense antenna switch. With R23 at minimum resistance, the pattern should not change. Slowly turn up R23 until the received signal is about as strong as it was at the peak of the loop pattern.

Now, with the sense enabled, rotate the receiver and you should find the signal off one end of the loop much weaker than that off the other side. Final adjustment is to point the end of the loop with the weaker signal at the transmitter and adjust R23 for the best null. (The important thing is to have enough difference between the two directions to tell which is stronger.) Be sure to mark which direction is weaker and which is stronger with the sense antenna activated.

You can change the direction of the null to point the other way by reversing the connections to L3. Be sure to recheck the sense antenna when readjusting C14.

Possible Construction Problems

Rick Campbell, KK7B, has an excellent description of common problems with direct conversion receivers in *Experimental Methods in RF Design*.¹³ There are two general types that may be encountered building this receiver: audio instability and microphonics. Audio instability is caused by the high audio gain in the receiver. The gain of the LM386 stage can be lowered by increasing R19. Try going from 470 Ω to 1 kΩ if you have a problem.

Eliminating common impedances in the dc and audio circuits also helps. The headphone jack should not be grounded to the case, but connected to ground only on the board near the junction of R19/R20. Similarly, connecting the positive battery lead directly to the hot end of R21 will reduce interaction in the dc line. Ordinary carbon-

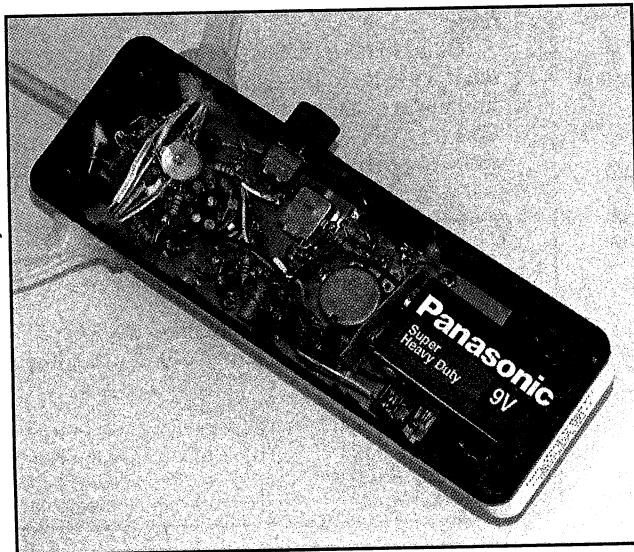

Figure 4—This early prototype of the 80-meter DF receiver uses a Radio Shack 270-1804 plastic case and “ugly construction.” The RF gain control can be operated with the thumb and the sense antenna switch with the index finger. The sense antenna circuit (Q5) is at the top, the RF amp (Q1 and Q2) is under the loop wiring and C14. T1 is secured with a drop of hot melt glue just left of R4. L4 is in the rectangular metal can just below S1, with Q3 just below it. U1 is on the left side just above the tuning control, R12. The headphone jack is beside the battery, and the plastic tubing for the loop antenna is glued to the case. The yellow wire for the sense antenna protrudes from the top.

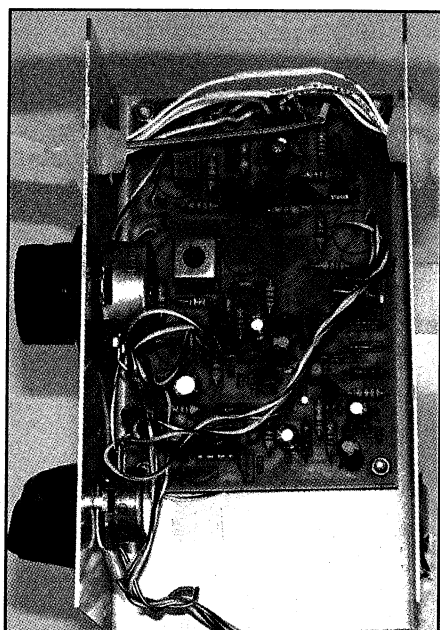
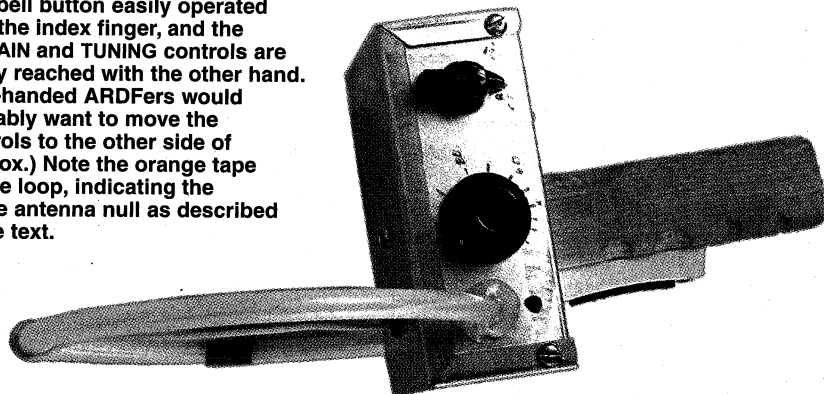

Figure 5—This version of the receiver uses the FAR Circuits PC board and a RadioShack 270-238 aluminum box. Because the box is a bit wide for most hands, this version is easier to use when mounted on a wooden handle. The SENSE switch is a doorbell button easily operated with the index finger, and the RF GAIN and TUNING controls are easily reached with the other hand. (Left-handed ARDFers would probably want to move the controls to the other side of the box.) Note the orange tape on the loop, indicating the sense antenna null as described in the text.



zinc batteries were found to be much more prone to audio feedback problems than alkaline or NiCd batteries because of the internal impedance.

Microphonics are one symptom of oscillator radiation reaching the antenna. A metal case is a big help. Mounting L4 with its axis at right angles to that of the loop antenna and dressing the loop wires away from the VFO section of the circuit board are also good ideas. Winding L4 on a toroid core would help, but it makes alignment more difficult.

Two other problems may arise when using a plastic case. A strong transmitter

signal can be picked up directly into the mixer wiring (bypassing the RF GAIN control), and the oscillator radiation may be heard in nearby receivers. Adding some shielding inside the case (aluminum foil or metal window screen) should help.

Operation

Operation is straightforward. Plug in the headphones and turn on the radio. Adjust the RF gain to max, and tune in the desired signal. Rotate the receiver to find the null in the pattern, where the signal strength is weakest. If the signal is too loud, turn down the RF gain. The signal source should be in a line perpendicular to the loop. To resolve which direction (ahead or behind you), turn the receiver 90° in either direction, switch in the sense antenna, and check the signal strength. Then rotate the loop 180° and compare. One end should be much stronger than

the other, and hopefully you marked which was which during calibration.

The loop will give the best DF results on vertically polarized ground wave signals. It will receive skywave signals, but may not be able to get a good null. Also, the sense antenna will start to work differently as you get within 100 feet or so of the transmitter antenna (the signal from the sense antenna will be stronger than that from the loop). There probably will still be some front-to-back ratio using the sense antenna, but it will not be as distinct as it is at longer distances.

For hunting interference in buildings, the power wiring will affect the properties of the loop. The receiver may work normally if the interference is radiating from a vertical wire, but if the wire is overhead the maximum signal will generally be when the loop is parallel to the direction of the wire carrying the

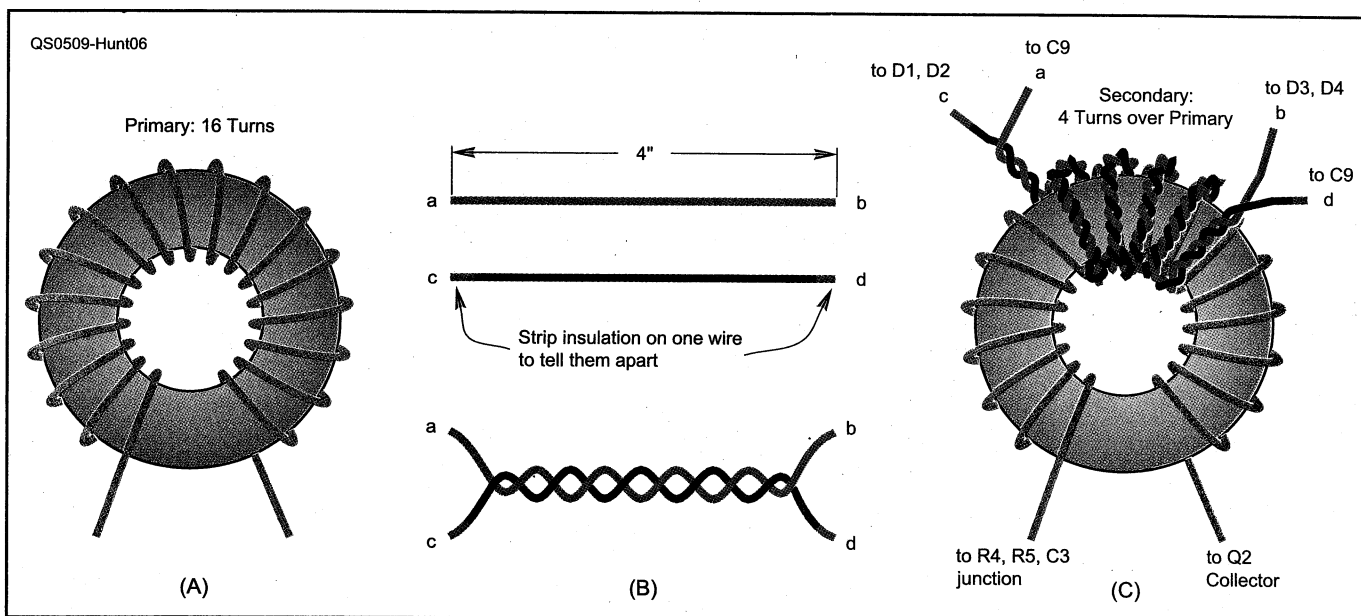

Figure 6—Construction details for T1, which is wound on an FT-37-43 with #26 or #28 enameled wire. First, wind the primary—16 turns of wire, spaced evenly to cover most of the core (A). Then cut two pieces of wire about 4 inches long for the secondary. Strip the insulation from the ends of one wire so you can tell them apart, and wind them together (B). Then wind the secondary, 4 turns, over top of the primary, beginning and ending at the opposite side of the core from the ends of the primary winding (C). Unwind the two strands from the secondary. Connect the stripped wire from one end of the secondary with the unstripped wire from the other end—this becomes the center tap. The remaining ends of the secondary go to the diodes in the mixer.

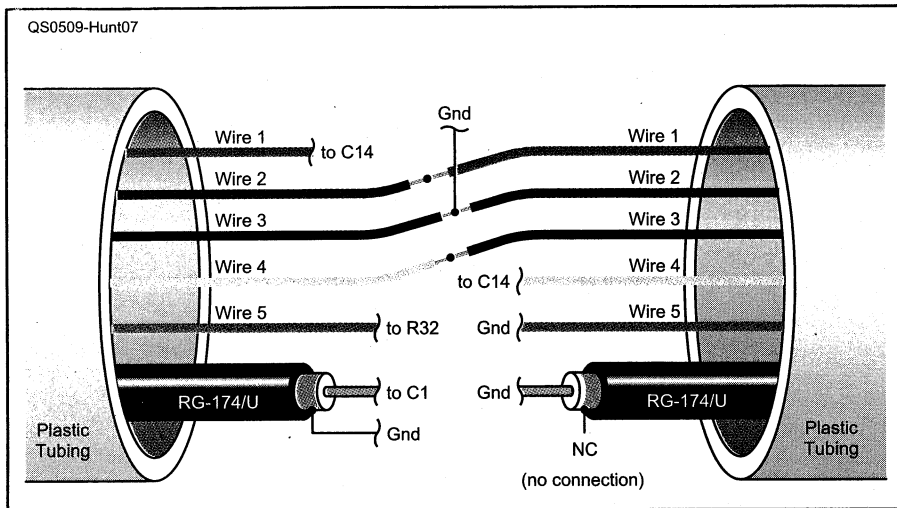

Figure 7—Wiring details of the loop antenna.

noise (caused by inductive coupling). Using the receiver to sniff for the strongest signal level may be the best approach in some cases.

Probably the most common cause of dead batteries is having the receiver switch on accidentally during transport. To prevent this, the receiver can be wired so power is only applied to the circuit when the headphone plug is inserted, as shown in Figure 9. The receiver turns off when the headphones are unplugged.

Does it work? Prototypes have identified a noisy fluorescent light fixture, tracked an interfering carrier on 3510 kHz, and found noise "hot spots" on power lines. And three hams have won medals in the national ARDF championships using versions of this receiver. ARDF is a fun and challenging activity. If you're interested in giving it a try, see the Region 2 ARDF Web site at www.ardf-r2.org for more information, links, equipment notes, calendar and so on.

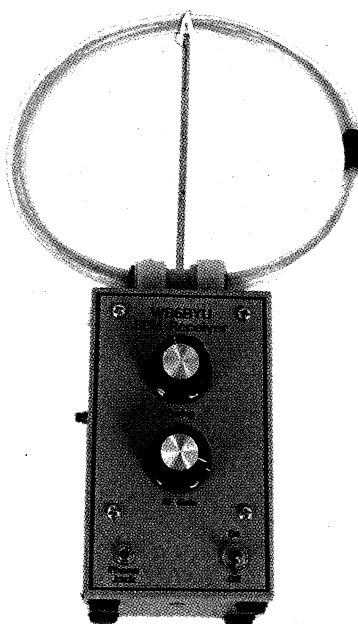
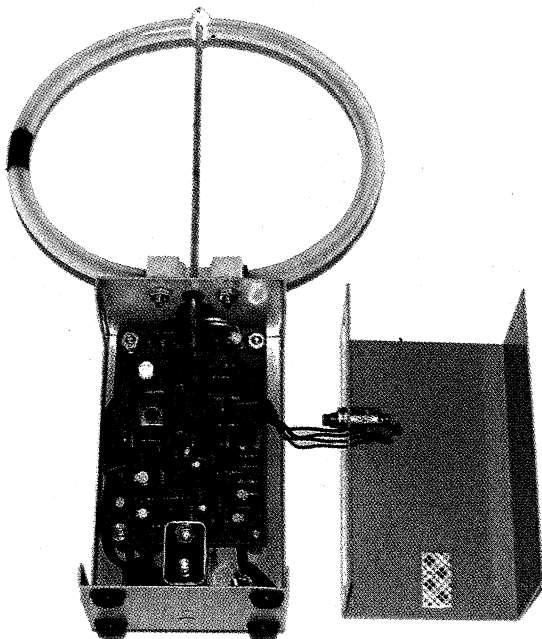

Figure 8—Here's a completed kit version of the receiver available from Marvin Johnston, KE6HTS (see Note 12).

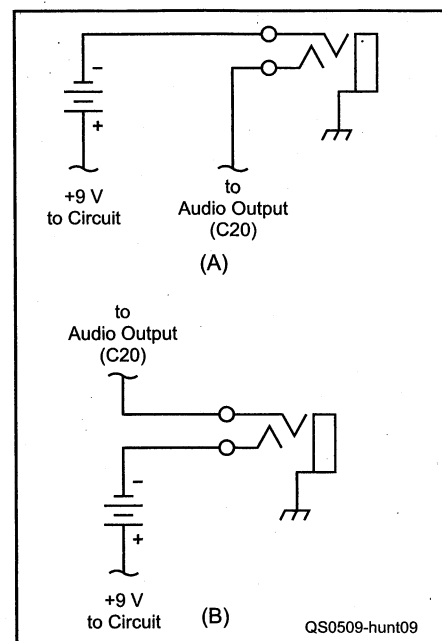

Figure 9—Two ways to use a stereo headphone jack to switch power. The version shown at (A) uses a 1/8 inch mono plug wired to the headphone in the normal manner. This method is simple, but momentarily applies power across the headphone as it is plugged in. The version shown at (B) avoids applying power across the headphone but requires a specially wired 1/8-inch stereo plug. (Wire the plug so the headphone connects between ring and sleeve and short the tip contact to the sleeve.)

Notes

- ¹R. Baldwin, "Amateur Radio Direction Finding in China," *QST*, Mar 1994, pp 22-24.
- ²D. Hunt, "Amateur Radio Direction Finding: The 1998 IARU World Championships," *QST*, May 1999, pp 28-31.
- ³J. Moell, "Amateur Radio Direction Finding: USA Holds Its First National Championships," *QST*, May 2001, pp 57-60.
- ⁴J. Moell, "80-Meter ARDF Comes to America," *73 Amateur Radio Today*, Nov 2000.
- ⁵B. Lenander, "M92—miniaturmottagare för 3,5 MHz CW/SSB," *QTC*, Apr 1992.
- ⁶G. Hoffschmidt, "80-m-Minipeiler," *cq-DL*, Sep 1979.
- ⁷R. Floesser, "Junior 80," *cq-DL*, Dec 1996.
- ⁸B. Lenander, "RX 91—en liten rävsax," *QTC*, Nov 1991.
- ⁹K. Taddey, "fuchsjagd—Peilempfänger Junior C," *cq-DL*, Jan 1977.

¹⁰R. Lewallen, "An Optimized QRP Transceiver," *QST*, Aug 1980, pp 14-19.

¹¹R. Campbell, "High-Performance Direct-Conversion Receivers," *QST*, Aug 1992, pp 19-28.

¹²The circuit board is available from FAR Circuits, 18N640 Field Ct, Dundee, IL 60118. For ordering information, see the FAR Circuits Web site at www.farcircuits.net and ask for the WB6BYU 80 m DF receiver board. For full and partial kits and prices, contact Marvin Johnston, KE6HTS, 408 Grove Ln, Santa Barbara, CA 93105, e-mail marvin@rain.org, or visit www.rain.org/~marvin/.

¹³W. Hayward, R. Campbell and B. Larkin, *Experimental Methods in RF Design* (Newington: 2003), section 8.3. Available from your local dealer, or from the ARRL Bookstore, ARRL order no. 8799. Telephone toll-free in the US 888-277-5289, or 860-594-0355, fax 860-594-0303; www.arrrl.org/shop/; pubsales@arrrl.org.

¹⁴Private correspondence with Bryan Ackerly, VK3YNG.

Dale Hunt was first licensed as WN6BYU in 1969 and holds an Amateur Extra class license. He has been participating in international ARDF events since 1996, and currently is the ARDF Coordinator for IARU Region 2. When not hunting transmitters or designing receivers, Dale works as a software engineer. He lives in Yamhill, Oregon, with his wife Kuon, KB7WRG, who is also an ARDF competitor. Dale can be reached at PO Box 108, Carlton, OR 97111 or wb6byu@arrrl.net. **QST**